

# Prelab Assignment

## Experiment 4

### ECE 482

Fig. 1 shows the power stage of the drivetrain boost converter assembled in experiment 3 along with the closed loop control and compensation circuitry to be implemented in experiment 4. For all parts of this prelab, consider operation of the boost converter with the following:

- $V_{bat} = 26\text{ V}$
- $V_{bus} = 26\text{-}75\text{ V}$
- $0\text{ W} < P_{out} < 150\text{ W}$

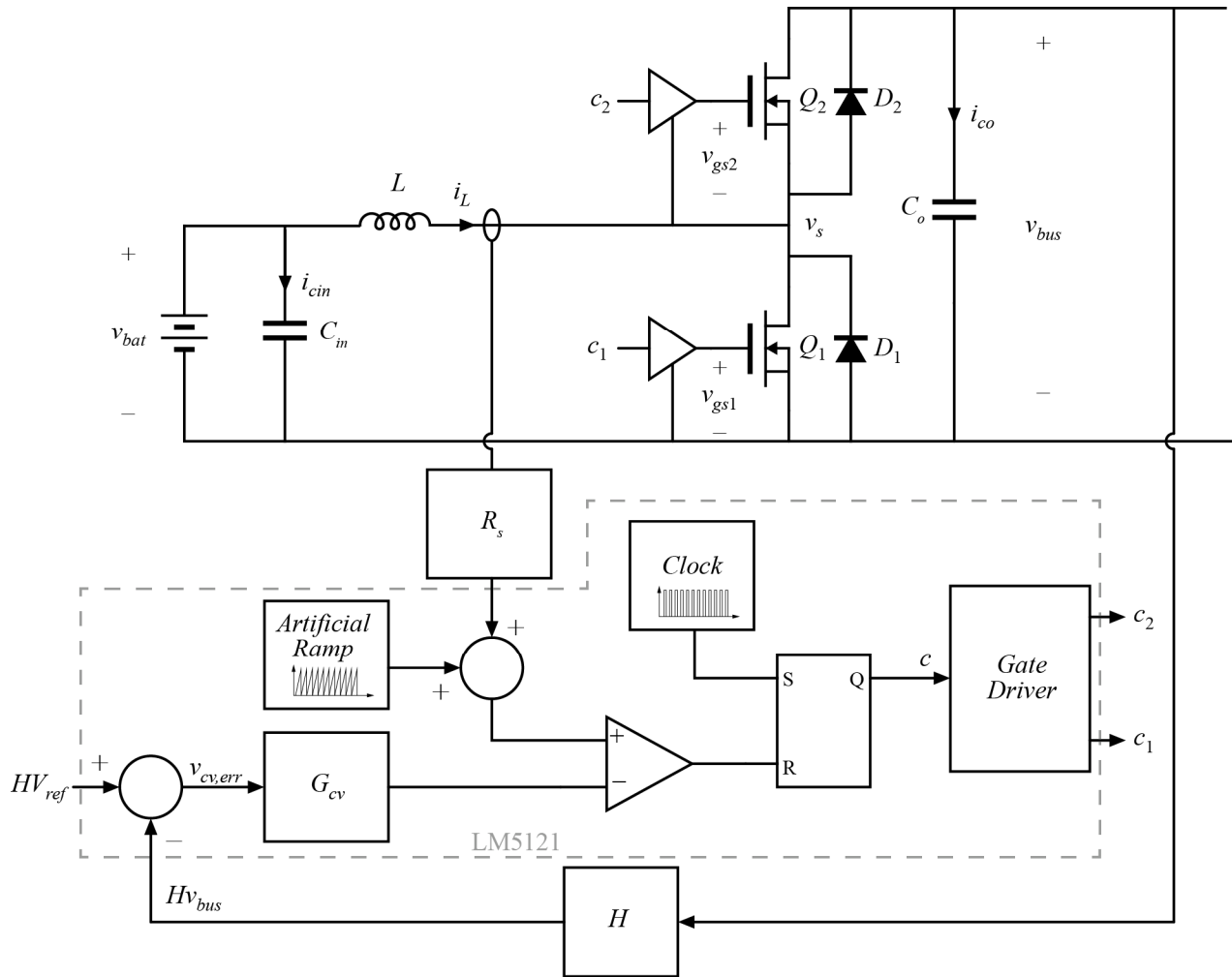

**Figure 1:** Closed-Loop Boost Converter

### Part 1: Boost Converter CPM Modeling

Using the simple first-order model discussed in class, and assuming small magnitudes of inductor current ripple and artificial ramp amplitude, solve (by hand) an analytical expression for the transfer function

$$G_{vi}(s) = \left. \frac{\hat{v}_{bus}}{\hat{i}_c} \right|_{\hat{v}_{bat}=0, \hat{i}_{bus}=0}$$

Sketch a plot of this transfer function at the operating point where  $P_{out} = 150 \text{ W}$  and  $V_{bus} = 50 \text{ V}$ . Based on this plot, design a compensator (i.e. construct  $G_{vc}(s)$ ) to provide stable, closed-loop voltage regulation. Sketch a plot of the loop gain  $T_v(s)$  for the voltage loop, and identify the DC gain, phase margin, and crossover frequency. You will need to make tradeoffs between each of these characteristics, but keep the following in mind:

- All crossover frequencies and closed-loop bandwidths must be well below the switching frequency of the converter. For crossover frequencies approaching the switching frequency, the (neglected) higher-order dynamics of CPM control become more significant.
- Low gains are desired at frequencies at and above the switching frequency in order to attenuate switching noise
- High (or infinite) DC gain is desired so that the control loops will accurately track their references in steady state
- $\phi_m > 0$  is required for stability, but larger phase margin is desirable to reduce overshoot and ringing

*Additional Comments:* Though you are only required to analyze one operating point in this prelab, keep in mind that your compensator will need to remain stable across all operating points. This will be examined further in Experiment 4 through simulation prior to implementing the closed-loop control.

## Part 2: Compensator Realization

Fig. 2 shows an example op-amp circuit capable of realizing a generic PID compensator. Depending on the design of your compensators from the previous section, this circuit may be appropriate for realizing the transfer functions you designed in Part 1. If your compensator is less complex, you may remove passive elements as necessary.

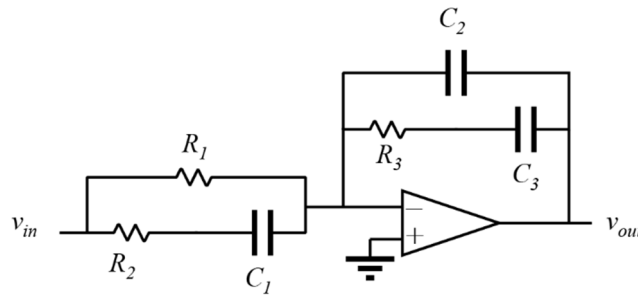

**Figure 2:** Op-amp compensation circuit

Starting from the circuit of Fig. 2 or using any other design approach, select values for the resistances and capacitances to realize your transfer function  $G_{vc}(s)$ .

## Part 3: Circuit Implementation

Read through the datasheet of the LM5121 boost converter controller posted on the website. There are many external IC connections which must be made in order to set operating modes and behaviors of the controller. Based on this application and the datasheet description of its operation, complete the schematic on the following page to show how you intend to connect each pin in-circuit. You do not need to sketch in the details of the boost converter that you have already built. You will be required to include the disconnect switch using the StrongIRFET from your parts kit. *Briefly* explain your decision for each connection, when alternatives are available.

HTSSOP  
PWP Package  
TOP VIEW

